

**Idrante a muro con tubazione flessibile da incasso "LINEA BASIC" DN 45 UNI EN 671-2**  
**Fire hydrant with lay-flat hose for recess installation "BASIC LINE" DN 45 UNI EN 671-2**

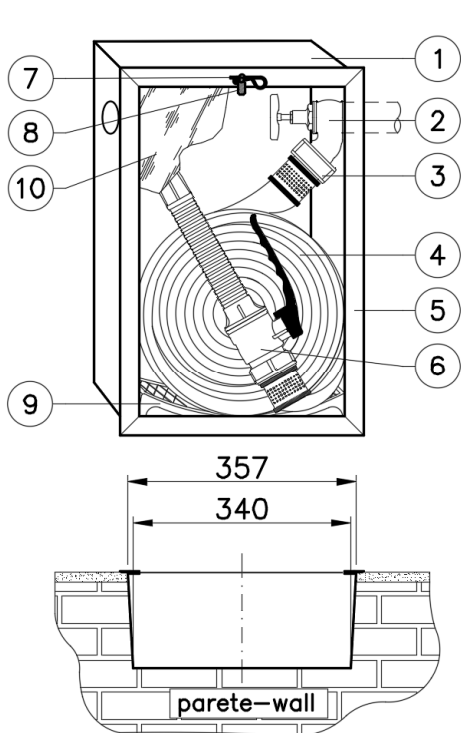

Vista inferiore – Bottom view

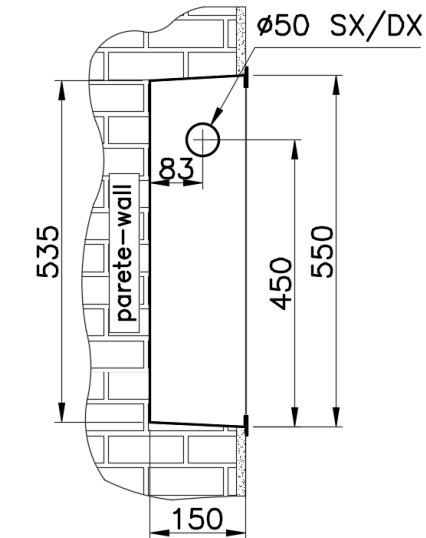

**Art. 2/AX**

Acciaio INOX AISI 430 non verniciato  
 Stainless Steel AISI 430 natural finish



N°	Cod.	Descrizione - description	Materiale - material
1	0689.035	Cassetta di contenimento (cod. indicato con telaio) Fire cabinet (the code shown includes frame)	Acciaio INOX AISI 430 non verniciato Not painted Stainless Steel AISI 430
2	0002.005	Rubinetto idrante DN 45x1"1/2 ISO 7 PN 16 Fire valve DN 45x1"1/2 ISO 7 PN 16	Ottone UNI - EN 1982 Brass UNI -EN 1982
3	0048.020	Raccordo DN 45 – UNI 804 forma C UNI 804 fire hose coupling DN 45 type C – Italian std.	Ottone UNI - EN 1982 Brass UNI -EN 1982
	0030.020	Raccordo DN 45 – UNI 804 forma C "AGILOK" UNI 804 fire hose coupling DN 45 type C – "AGILOK"	Lega leggera UNI - EN 586-2 Light alloy UNI - EN 586-2
4	ART.30/A	Tubazione flessibile DN 45 UNI-EN 14540 mod. AB-PU Fire hose AB-PU DN 45 UNI – EN 14540	Calza in poliestere alta tenacità Jacket in high tenacity polyester
5	0906.039	Telaio portavetro dim.575x382mm Frame dim. 575x382mm	Alluminio anodizzato Anodized aluminum
6	2145D13.074	Lancia frazionatrice a leva "STARJET" DN 45 Ø 13 corpo ottone "STARJET" branchpipe DN 45 Ø 13 brass body	Ottone / polipropilene Brass / polypropylene
	2146D13.074	Lancia frazionatrice a leva "STARJET" DN 45 Ø 13 corpo alluminio "STARJET" branchpipe DN 45 Ø 13 light alloy body	Alluminio / polipropilene / ottone Light alloy / polypropylene / brass
7	M60750	Fermaglio – Clip	Acciaio INOX - Stainless Steel
8	M65200	Sigillo - Seal	Plastica - Plastic
9	0914.250	Sostegno per tubazione - Hose support	Polipropilene - Polypropylene
10	40011.700	Lastra "FIRE GLASS" – Fire glass for cabinet	Plastica - Plastic

(Portata – Coefficiente K effettivo – Gittata) - (Flow rate – K factor – Throw distance):  
 Lancia "STARJET" DN 45 con foro ugello 13 mm - "STARJET" branchpipe with outlet 13 mm)

Posizione maniglia Handle Position	K	Portata riscontrata in prova – Real flow rate Q [l/min] @			Gittata - Throw distance @ 0,2 MPa [m]	
		0,2 MPa	0,4 MPa	0,6 MPa	Max	Eff.
Getto pieno - Full jet	101,2	143	202	248	21,0	18,9
Getto frazionato - Spray jet	85	120	170	208	6,6	5,94
<b>NOTE</b>	<b>K minimo previsto dalla norma e utilizzato nella DoP Min. K factor reported from standard and employed in DoP document</b>				<b>K=85</b>	
<b>Q [l/min] = K*√10p [MPa]</b>		Angolo di erogazione con getto frazionato - Spray angle			<b>45°</b>	

Tolleranze generali [mm] General tolerances [mm]	± 4
---	-----

Spessore min. lamierato Minimum plate tickness	6/10
---	------

Peso - Weight	
Con tubazione 15 m With 15 m hose length	10 kg
Con tubazione 20 m With 20 m hose length	11 kg
Con tubazione 25 m With 25 m hose length	12 kg
Con tubazione 30 m With 30 m hose length	13 kg



**BOCCIOLONE ANTINCENDIO S.p.A.**

unipersonale  
 Via Giacomo Grai, 1 – 28078 Romagnano Sesia (NO) – ITALY  
 TEL: 0163 – 568811  
 e-mail: info@bocciolone.com - www.bocciolone.com

SCHEDA TECNICA - DATA SHEET ST – 2AX – 02	
Descrizione - description	Art.
Idrante a muro da incasso DN 45 "BASIC LINE". Lancia STARJET Ø 13- Fire hydrant DN 45 "BASIC LINE" STARJET branchpipe Ø 13.	<b>2/AX</b>
Rev. 3	Data – Date: 14/02/2025